

## Oil electrical level indicators

with MIN level and MAX temperature electrical sensors

### MATERIAL

Transparent polyamide based (PA-T) technopolymer. Highly resistant to shocks, solvents, oils with additives, aliphatic and aromatic hydrocarbons, petrol, naphtha, phosphoric esters. Avoid contact with alcohol or detergents containing alcohol.

### SCREWS, NUTS AND WASHERS

Zinc-plated steel.

### PACKING RINGS

Step-shaped for the seal on the reservoir walls and NBR synthetic rubber O-ring under screw head. Suggested roughness of the packing ring application surface  $R_a = 3 \mu\text{m}$ .

### FLOAT

Glass-fibre reinforced polyamide based (PA) technopolymer, black colour, with a built-in magnetic element to activate the electric contact when the float reaches the contact threshold located at about 50 mm above the axis of the lower screw (data referred to mineral oil type CB68, according to ISO 3498, temperature 23°C).

### BRACKET WITH LEVEL AND TEMPERATURE SENSORS.

Watertight in glass-fibre reinforced polyamide based (PA) technopolymer, black colour, with a built-in relay (reed) with two conductors and a MAX temperature sensor (80°C). For a correct assembly see Warnings (on page ).

### SWIVELLING CONNECTOR

With built-in cable gland and contact holder. Front or axial output (high or low) ensuring protection against water sprays (protection class IP 65 according to table EN 60529 table see page ).

### CONTRAST SCREEN

White lacquered aluminium. The housing, in the appropriate external rear slot, guarantees the best protection from direct contact with fluid. It can be taken out from the inclined side, before assembly to allow the insertion of level lines or words.

### STANDARD EXECUTIONS

- **HCV-E-ST-NO**: with electric contacts normally open (NO).
- **HCV-E-ST-NC**: with electric contacts normally closed (NC).

### MAXIMUM CONTINUOUS WORKING TEMPERATURE

90°C (with oil).

### FEATURES AND PERFORMANCES

In addition to the visual control, HCV-E-ST column level indicator, generates also an electric signal when the oil level drops to a minimum and an electric signal when the temperature reaches the max pre-set degrees (80°C). Ultrasound welding to guarantee a perfect seal. Thanks to the side output of the connector, HCV-E-ST level indicator allows to minimise the level of intervention of the sensor. Maximum fluid level visibility even from side positions. Lens effect for a better visibility of the fluid level.

### TECHNICAL DATA

In laboratory tests carried out with mineral oil type CB68 (according to ISO 3498) at 23°C for a limited period of time, the weld stood up to: 18 bar (HCV.127) 12 bar (HCV.254). For use with other fluids and under different pressure and temperature conditions, please contact ELESA Technical Department. In any case we suggest to verify the suitability of the product under the actual working conditions.



ELESA Original design

### SPECIAL EXECUTIONS ON REQUEST

- Level indicators with stainless steel screws, nuts and washers.
- Level indicators HCV.76 with screws M12.
- Level indicators for use with fluids containing alcohol.
- UV resistant transparent technopolymer level indicators.
- MAX temperature electrical sensor with trigger threshold at 70°C or 90°C.

### CONNECTOR ASSEMBLY INSTRUCTIONS

1. Remove the connector from the indicator by unscrewing the set screw placed on the connector, take the contact holders out and loosen the cable gland.
2. Slip on the cable into the connector (standard connector) and connect the wires to the terminals 1 and 2 for the functioning of the MIN level sensor, to the terminals 3 and earth for the functioning of the MAX temperature sensor.
3. Assemble by pressing the contact holder into the connector in the required position.
4. Screw the connectors to the indicator and then tighten the cable glands.

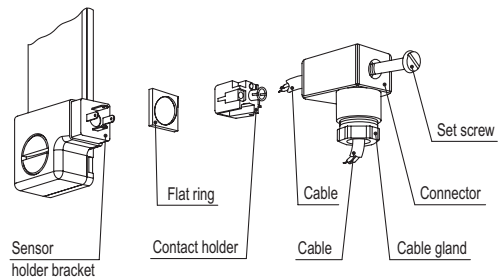

### FUNCTIONING OF THE SENSORS

- HCV-E-ST-NO: the electrical contact closes when the minimum level and/or the pre-set temperature at 80°C is reached.
- HCV-E-ST-NC: the electrical contact opens when the minimum level and/or the pre-set temperature at 80°C is reached.

Electrical features	MAX temperature sensor	
Tension feed	AC/DC	
Electric contacts	NO normally open NC normally closed	
Voltage / Maximum current	250 Vac - 2 A	(resistive loads)
	115 Vac - 3 A	
	24 Vdc - 3 A	
	12 Vdc - 4 A	
Minimum current	50 mA	
Cable gland	Pg 7 (for cables in sheath with Ø 6 or 7 mm)	
Conductors cross-section	Max. 1.5 mm <sup>2</sup>	

Electrical features	MIN level sensor
Tension feed	AC/DC
Electric contacts	NO normally open NC normally closed
Maximum applicable voltage	NO: 140 Vac, 200 Vdc NC: 140Vac, 150 Vdc
Maximum switching current	1 A
Maximum current	NO: 1.2A NC: 2A
Maximum commutable power	NO: 10 Va NC: 20 Va
Cable gland	Pg 7 (for cables in sheath with Ø 6 or 7 mm)
Conductors cross-section	Max. 1.5 mm <sup>2</sup>
Do not mount this indicator in proximity to magnetic fields.	

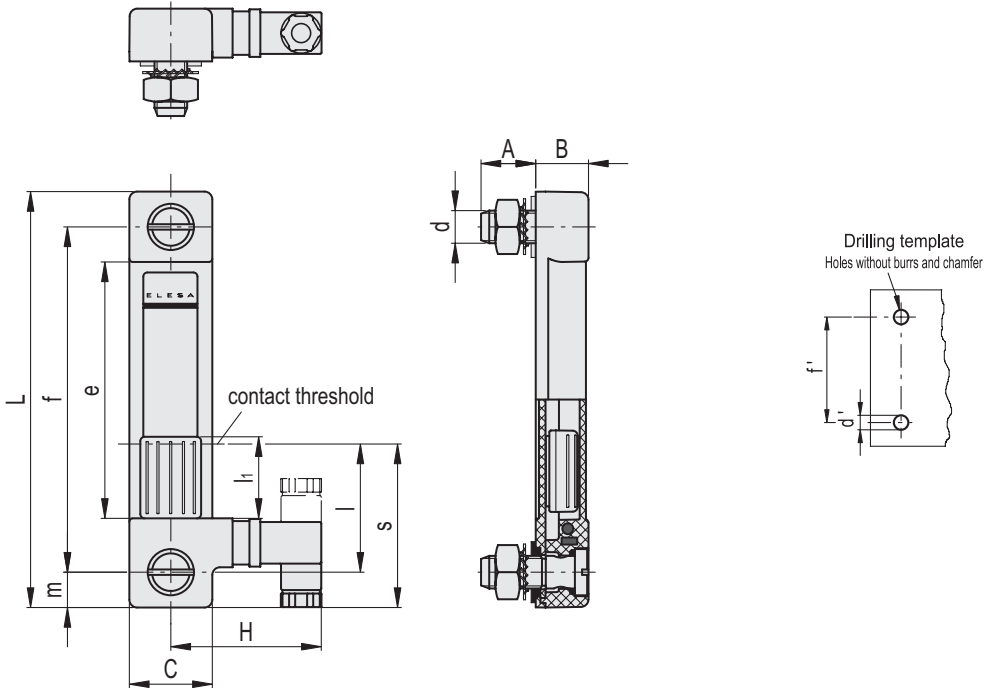
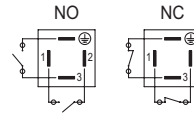

Code	Description	f	d	A	B	C	H	L	e	l	li	m	s	d'-0.2	f'±0.2	C# [Nm]	⚖
11054	HCV.76-E-ST-NO-M10	76	M10	20	19.5	30.5	55	102	43.5	40	20	13	53	10.5	76	12	133
11055	HCV.76-E-ST-NC-M10	76	M10	20	19.5	30.5	55	102	43.5	40	20	13	53	10.5	76	12	133
11115	HCV.127-E-ST-NO-M12	127	M12	20	19.5	30.5	55	153	97	50	30	13	63	12.5	127	12	153
11116	HCV.127-E-ST-NC-M12	127	M12	20	19.5	30.5	55	153	97	50	30	13	63	12.5	127	12	153
11125	HCV.254-E-ST-NO-M12	254	M12	20	19.5	30.5	55	280	224	50	30	13	63	12.5	254	12	180
11126	HCV.254-E-ST-NC-M12	254	M12	20	19.5	30.5	55	280	224	50	30	13	63	12.5	254	12	180

# Maximum tightening torque

