

GN 589

Lifting points

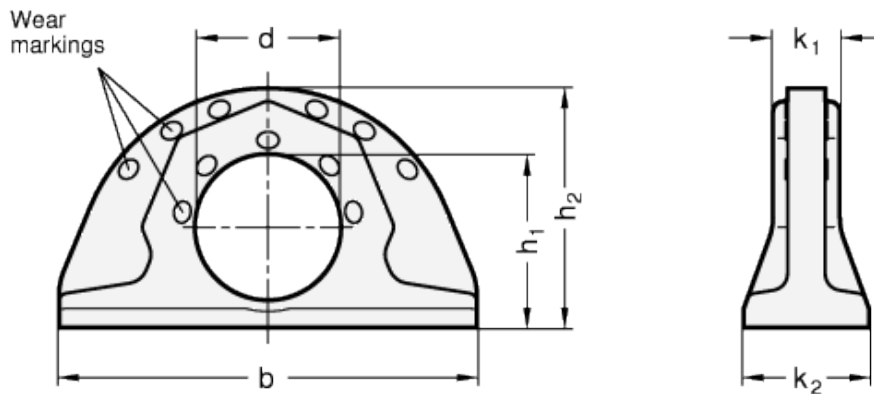

technical informations

Material

High-tensile forged tempered steel 1.6541, 100% electro-magnetic tensile tested to EN 1677, phosphated.

Features and applications

Lifting points GN 589 are distinguished for their very low dimensions. They provide high dynamic and static strength and can be load from any direction with approved safety (safety factor 4) for all loading directions.

The rated load carrying capacity listed in the above table is clearly marked on the lifting point. It applies to the most unfavourable load application of the load types listed opposite.

Lifting points GN 589 comply with Mechanical Engineering Directive 2006 / 42 / EG.

Method of mounting										
Number Angles of inclination factor	1 0° 1	1 90° 1	2 0° 2	2 90° 2	2 0 to 45° 1,4	2 45 to 60° 1	2 asymm. 1	3 and 4 0 to 45° 2,1	3 and 4 45 to 60° 1,5	3 and 4 asymm. 1
b = 100	1,6 t	1,6 t	3,2 t	3,2 t	2,2 t	1,6 t	1,6 t	3,4 t	2,4 t	1,6 t
137	3,2 t	3,2 t	6,4 t	6,4 t	4,5 t	3,2 t	3,2 t	6,8 t	4,8 t	3,2 t
172	5,0 t	5,0 t	10,0 t	10,0 t	7,1 t	5,0 t	5,0 t	10,6 t	7,5 t	5,0 t
228	10,0 t	10,0 t	20,0 t	20,0 t	14,1 t	10,0 t	10,0 t	21,2 t	15,0 t	10,0 t

Safety instructions

The above details specify the maximum load in metric tonnes.



Use permitted
No traces of wear

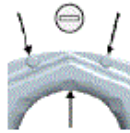

Use not permitted
Criteria reached:
Material worn down
to the wear marks

Carefully check the wear markings for the abrasion of the lifting point.

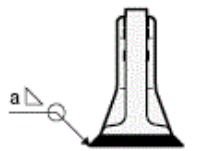

Welding seam

Lifting point	Size fillet seam	Length	Volume in cm ³
b = 100 (1,6 t)	a = 4	251	4,016
137 (3,2 t)	6	344	12,38
172 (5,0 t)	7	431	21,10
228 (10,0 t)	8	576	36,86

Welding must be made by an approved welder in accordance with EN 287-1.

The specified loading values are valid for an operating temperature of between -40 °C and +200 °C. Load capacities under higher temperatures provided on request.

Operating instructions with more details and specifications are included with every delivery.

Standard Elements	Main dimensions						Nominal load in t (WLL)	max. permitted lashing force in daN (LC)	Weight g
	Description	b	d	h ₁	h ₂	k ₁ k ₂			
GN 589-100	100	35	41.5	57	16	30	1.6	3200	435
GN 589-137	137	50	59	80	23	41	3.2	6400	1100
GN 589-172	172	60	71.5	99	27	51	5	10000	2160
GN 589-228	228	80	95	100	38	70	10	20000	2870



ELESA and GANTER models all rights reserved in accordance with the law. Always mention the source when reproducing our drawings.

STANDARD MACHINE ELEMENTS WORLDWIDE