

GN 115.10

Latches with gripping tray

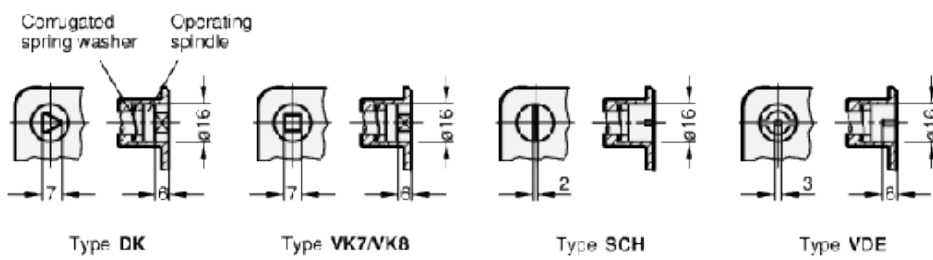
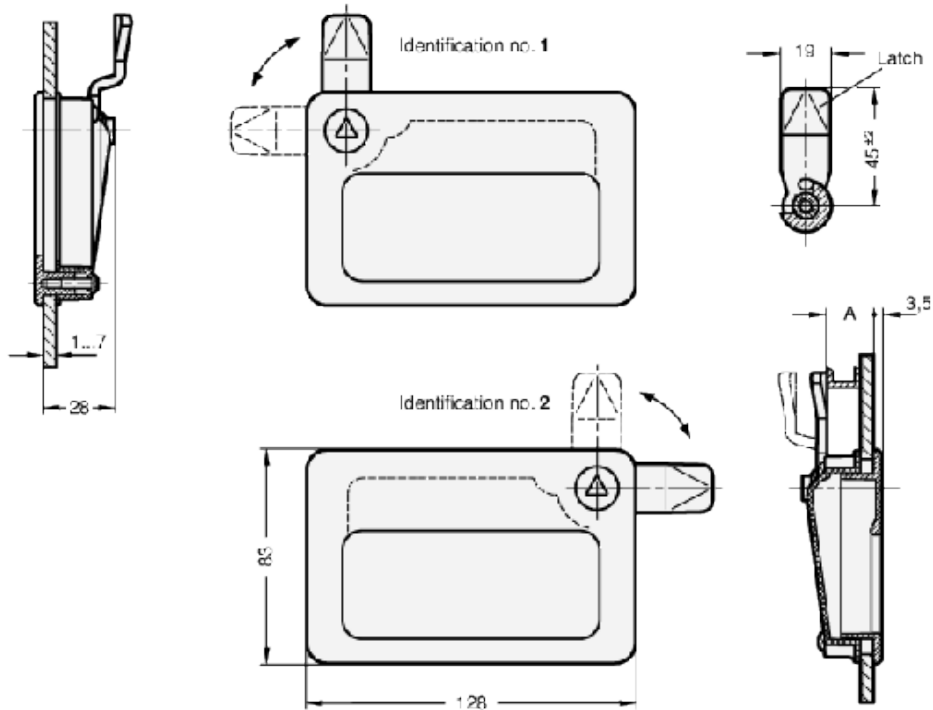

Type

- Type DK: Operation with triangular spindle (DK7)
- Type VK7: Operation with square spindle A/F7
- Type VK8: Operation with square spindle A/F8
- Type SCH: Operation with slot
- Type VDE: Operation with double bit

Identification no.

- Version 1: Operation in standard mounting position, at the top left
- Version 2: Operation in standard mounting position, at the top right

Front frame

Zinc die casting
plastic coated
black, RAL 9005, textured finish SW
silver, RAL 9006, textured finish SR

Tray

Plastic
- black grey (for SW)
- light grey (for SR)

Operating part

Zinc die casting
- plastic coated, black (for SW)
- chrome-plated (for SR)

other parts

Steel
zinc plated, blue passivated

Information

Latches with gripping tray GN 115.10 are used in applications which require a moulded recess in addition to the latching mechanism, e.g. if operating elements are not allowed to protrude for reasons of space.

A rotary movement limited to 90°, e.g. of the three-edged wedge in type DK, moves the latch behind the frame, with the run-up bevels at the latch making it easier to close the door.

Latches with 22 different cranks cover a latch distance A from 4 to 50 mm. Latches GN 115.10 are supplied with loosely enclosed locking.

Accessory

- Keys GN 119.2

Construction and assembly instructions

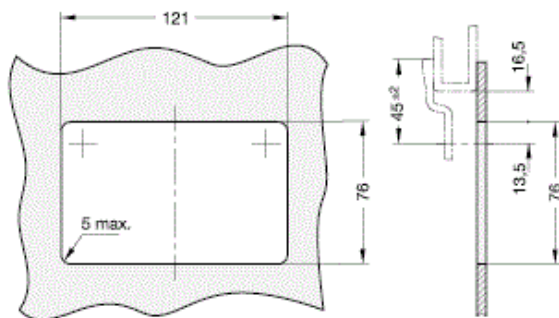

Before assembly, a nick must be made in the door as shown in the drawing below.

Depending on position of the latch, the 16,5 mm edge spacing between frame and nick must be ensured sideways and / or top and bottom to make sure that the latch is positioned behind the frame.

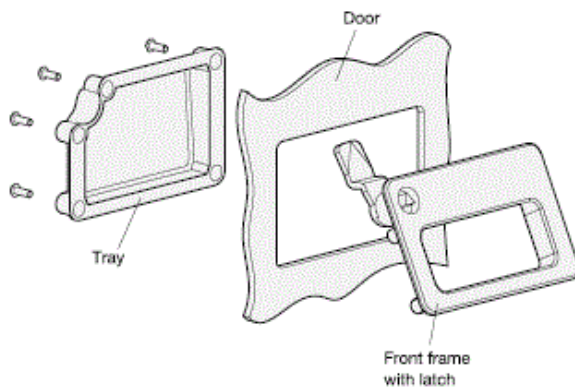

For the assembly, insert the front frame together with the pre-assembled latch from the front through the nick of the door by tilting.

Place the plastic tray from the back onto the bore pegs of the front frame.

The M4x12 fillister-head screws included are then screwed in from the rear and tightened to fix and wedge the whole unit in place. The minimum screw-in depth of the screw is guaranteed with a maximum door wall thickness of 7 mm.

Assembly example

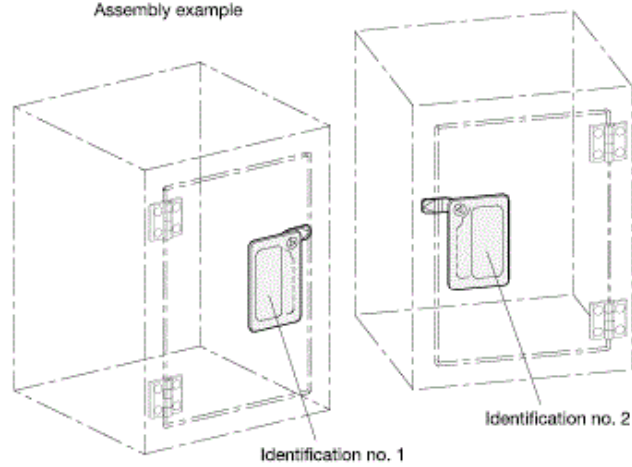

Standard Elements	Main dimensions	Weight
Description	A	g
GN 115.10-* -4-1-SW	4	-
GN 115.10-* -4-1-SR	4	-
GN 115.10-* -6-1-SW	6	-
GN 115.10-* -6-1-SR	6	-
GN 115.10-* -8-1-SW	8	-
GN 115.10-* -8-1-SR	8	-
GN 115.10-* -10-1-SW	10	-
GN 115.10-* -10-1-SR	10	-
GN 115.10-* -13-1-SW	13	-
GN 115.10-* -13-1-SR	13	-
GN 115.10-* -14-1-SW	14	-
GN 115.10-* -14-1-SR	14	-
GN 115.10-* -16-1-SW	16	-
GN 115.10-* -16-1-SR	16	-
GN 115.10-* -18-1-SW	18	-
GN 115.10-* -18-1-SR	18	-
GN 115.10-* -20-1-SW	20	-
GN 115.10-* -20-1-SR	20	-
GN 115.10-* -22-1-SW	22	-
GN 115.10-* -22-1-SR	22	-
GN 115.10-* -24-1-SW	24	-
GN 115.10-* -24-1-SR	24	-
GN 115.10-* -26-1-SW	26	-
GN 115.10-* -26-1-SR	26	-
GN 115.10-* -28-1-SW	28	-
GN 115.10-* -28-1-SR	28	-
GN 115.10-* -30-1-SW	30	-
GN 115.10-* -30-1-SR	30	-
GN 115.10-* -32-1-SW	32	-
GN 115.10-* -32-1-SR	32	-
GN 115.10-* -34-1-SW	34	-

GN 115.10-* -34-1-SR	34	-
GN 115.10-* -36-1-SW	36	-
GN 115.10-* -36-1-SR	36	-
GN 115.10-* -38-1-SW	38	-
GN 115.10-* -38-1-SR	38	-
GN 115.10-* -40-1-SW	40	-
GN 115.10-* -40-1-SR	40	-
GN 115.10-* -42-1-SW	42	-
GN 115.10-* -42-1-SR	42	-
GN 115.10-* -45-1-SW	45	-
GN 115.10-* -45-1-SR	45	-
GN 115.10-* -50-1-SW	50	-
GN 115.10-* -50-1-SR	50	-
GN 115.10-* -4-2-SW	4	-
GN 115.10-* -4-2-SR	4	-
GN 115.10-* -6-2-SW	6	-
GN 115.10-* -6-2-SR	6	-
GN 115.10-* -8-2-SW	8	-
GN 115.10-* -8-2-SR	8	-
GN 115.10-* -10-2-SW	10	-
GN 115.10-* -10-2-SR	10	-
GN 115.10-* -13-2-SW	13	-
GN 115.10-* -13-2-SR	13	-
GN 115.10-* -14-2-SW	14	-
GN 115.10-* -14-2-SR	14	-
GN 115.10-* -16-2-SW	16	-
GN 115.10-* -16-2-SR	16	-
GN 115.10-* -18-2-SW	18	-
GN 115.10-* -18-2-SR	18	-
GN 115.10-* -20-2-SW	20	-
GN 115.10-* -20-2-SR	20	-
GN 115.10-* -22-2-SW	22	-
GN 115.10-* -22-2-SR	22	-
GN 115.10-* -24-2-SW	24	-
GN 115.10-* -24-2-SR	24	-
GN 115.10-* -26-2-SW	26	-
GN 115.10-* -26-2-SR	26	-
GN 115.10-* -28-2-SW	28	-
GN 115.10-* -28-2-SR	28	-
GN 115.10-* -30-2-SW	30	-
GN 115.10-* -30-2-SR	30	-
GN 115.10-* -32-2-SW	32	-
GN 115.10-* -32-2-SR	32	-
GN 115.10-* -34-2-SW	34	-
GN 115.10-* -34-2-SR	34	-

GN 115.10-* -36-2-SW	36	-
GN 115.10-* -36-2-SR	36	-
GN 115.10-* -38-2-SW	38	-
GN 115.10-* -38-2-SR	38	-
GN 115.10-* -40-2-SW	40	-
GN 115.10-* -40-2-SR	40	-
GN 115.10-* -42-2-SW	42	-
GN 115.10-* -42-2-SR	42	-
GN 115.10-* -45-2-SW	45	-
GN 115.10-* -45-2-SR	45	-
GN 115.10-* -50-2-SW	50	-
GN 115.10-* -50-2-SR	50	-

*Complete the description of the standard item needed by adding DK (with triangular spindle), VK7 (with square spindle A/F7), VK8 (with square spindle A/F8), SCH (with slot) or VDE (with double bit).



STANDARD MACHINE ELEMENTS WORLDWIDE