

# GN 822.7

Mini indexing plungers

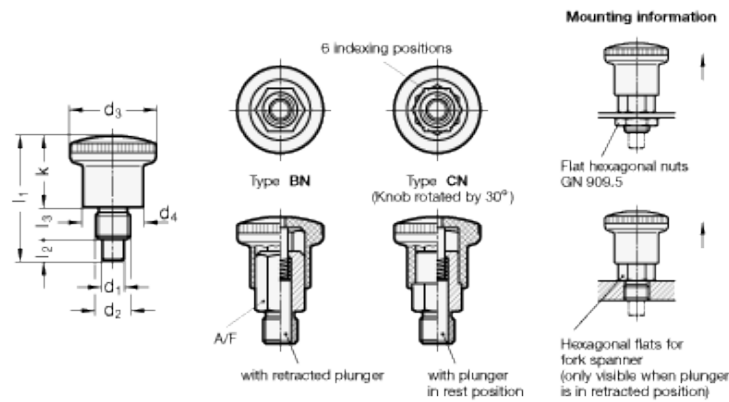

INOX  
Stainless Steel



## technical informations

**Threaded body**  
AISI 303 stainless steel.

## Plunger

AISI 303 stainless steel. Suggested matching hole with tolerance +0.03/+0.08.

## "Push/Pull" knurled knob

Stainless Steel AISI 305, matt blasted, not removable.

## Spring

AISI 301 stainless steel.

## Standard versions available

- Type BN: without rest Position, with Stainless Steel-Knob.
- Type CN: with rest Position, with Stainless Steel-Knob.

## Accessories on request

- Distance bushings GN 609 / GN 609.5.
- Flat hexagonal nuts GN 909.5.

## Features and applications

Stainless Steel-Mini indexing plungers GN 822.7 are distinguished for their small dimensions. Based on the principle of the mini indexing plungers GN 822, this model combines their clever type of construction with a complete series of all current sizes of bolts and threads. They provide a reasonably priced alternative to the GN 607 / GN 607.1 indexing plungers of the appropriate sizes. To mount, first turn the mini indexing plunger in with the knurled button.

Pulling the indexing pin will release the hexagon nut which can then be tightened with an open-end spanner. The spanner flats on the lock nut are revealed when retracting the pin, so that the mini indexing plunger can be easily tightened by means of a fork spanner.  
In type CN, the button can be turned by 30° after retracting the indexing pin, holding it in the "retracted" position using the indexing lock.

Standard Elements	Main dimensions									Spring pressure in N $\approx$		Weight
	Description	d <sub>1 h9</sub>	d <sub>2</sub>	d <sub>3</sub>	d <sub>4</sub>	l <sub>1</sub>	l <sub>2 min.</sub>	l <sub>3</sub>	k	A/F	Preload	
GN 822.7-4-M8-BN	4	M8	21	15	27.5	5	6	16.5	10	4	12	14
GN 822.7-5-M10-BN	5	M10	25	18	34	6	8	20	12	6	16	25
GN 822.7-6-M10-BN	6	M10	25	18	34	6	8	20	12	6	18	20
GN 822.7-6-M12-BN	6	M12	28	20	40.5	7	10	23.5	14	10	23	30
GN 822.7-7-M12-BN	7	M12	28	20	40.5	7	10	23.5	14	10	23	30
GN 822.7-8-M16-BN	8	M16	33	23	47.5	10	12	25.5	17	11	35	66
GN 822.7-10-M16-BN	10	M16	33	23	47.5	10	12	25.5	17	11	35	70
GN 822.7-4-M8x1-BN	4	M8x1	21	15	27.5	5	6	16.5	10	4	12	14
GN 822.7-5-M10x1-BN	5	M10x1	25	18	34	6	8	20	12	6	16	25
GN 822.7-6-M10x1-BN	6	M10x1	25	18	34	6	8	20	12	6	16	25
GN 822.7-6-M12x1.5-BN	6	M12x1.5	28	20	40.5	7	10	23.5	14	10	23	30
GN 822.7-7-M12x1.5-BN	7	M12x1.5	28	20	40.5	7	10	23.5	14	10	23	30
GN 822.7-8-M16x1.5-BN	8	M16x1.5	33	23	47.5	10	12	25.5	17	11	35	67
GN 822.7-10-M16x1.5-BN	10	M16x1.5	33	23	47.5	10	12	25.5	17	11	35	70
GN 822.7-4-M8-CN	4	M8	21	15	27.5	5	6	16.5	10	4	12	13
GN 822.7-4-M8x1-CN	4	M8x1	21	15	27.5	5	6	16.5	10	4	12	14
GN 822.7-5-M10-CN	5	M10	25	18	34	6	8	20	12	6	16	24
GN 822.7-6-M10-CN	6	M10	25	18	34	6	8	20	12	6	16	24
GN 822.7-6-M12-CN	6	M12	28	20	40.5	7	10	23.5	14	10	23	29
GN 822.7-7-M12-CN	7	M12	28	20	40.5	7	10	23.5	14	10	23	29
GN 822.7-8-M16-CN	8	M16	33	23	47.5	10	12	25.5	17	11	35	64
GN 822.7-10-M16-CN	10	M16	33	23	47.5	10	12	25.5	17	11	35	65
GN 822.7-5-M10x1-CN	5	M10x1	25	18	34	6	8	20	12	6	16	24
GN 822.7-6-M10x1-CN	6	M10x1	25	18	34	6	8	20	12	6	16	24
GN 822.7-6-M12x1.5-CN	6	M12x1.5	28	20	40.5	7	10	23.5	14	10	23	29
GN 822.7-7-M12x1.5-CN	7	M12x1.5	28	20	40.5	7	10	23.5	14	10	23	29
GN 822.7-8-M16x1.5-CN	8	M16x1.5	33	23	47.5	10	12	25.5	17	11	35	65
GN 822.7-10-M16x1.5-CN	10	M16x1.5	33	23	47.5	10	12	25.5	17	11	35	67



STANDARD MACHINE ELEMENTS WORLDWIDE